

PS600 HR/C

Solar-operated Submersible Pump System, 4" Helical Rotor (HR) or Centrifugal (C) Pump Unit

Characteristics

- lift up to 180 m
- flow rate up to 11 m³/h
- simple installation
- maintenance-free
- high reliability and life expectancy
- cost-efficient pumping

Applications

- drinking water supply
- livestock watering
- pond management
- irrigation
- etc.

Components

Controller PS600

- controlling of the pump system and monitoring of the operating states
- mounted at surface (no electronic parts submerged)
- two control inputs for well probe (dry running protection), float or pressure switches, remote control etc.
- automatic reset 20 minutes after well probe turns pump off
- protected against reverse polarity, overload and high temperature
- speed control, max. pump speed adjustable to reduce flow rate to c. 30 %
- solar operation: integrated MPPT (Maximum Power Point Tracking)
- battery operation: low voltage disconnect and restart after battery has recovered
- max. efficiency 92 % (motor + controller)
- enclosure: IP 54 (sealed, weatherproof)

Motor ECDRIVE 600HR/C

- brushless DC motor
- no electronics inside motor
- water filled
- IP68, pressure balanced, unlimited submersion
- dynamic slide bearings, material: carbon/ceramic
- wetted material: stainless steel (AISI 316), POM, rubber, cable drinking water approved

Pump End (PE)

- high life expectancy
- non-return valve
- dry running protection (optional)
- material: stainless steel (AISI 316), rubber

HR Pumps Only

- helical rotor pump (positive displacement pump)
- two main parts only: stator and rotor, field serviceable
- stator: geometry made of abrasion resistant rubber
- rotor: stainless steel, hard chrome plated, abrasion resistant
- more resistant to damage by sand than other pump types
- self-cleaning

Performance

PS600	HR-03	HR-03H	HR-04	HR-04H
article #	1040-X	1045-X	1050-X	1055-X
lift [m]	0-140	140-180	0-80	80-140
max. flow rate [m ³ /h]	0.5	0.5	0.8	0.8
max. efficiency [%]	60	64	60	65
solar operation	nominal voltage 48-72VDC, open circuit voltage max. 150VDC			
solar generator [Wp]	300-480	420-900	300-480	420-900
battery operation	nominal voltage 48VDC			
PS600	HR-07	HR-14	C-SJ5-8	C-SJ8-7
article #	1060-X	1070-X	1292	1293
lift [m]	40-90	0-50	0-25	0-18
max. flow rate [m ³ /h]	1.2	2.7	7.5	11.0
max. efficiency [%]	64	65	47	47
solar operation	nominal voltage 48-72VDC, open circuit voltage max. 150VDC			
solar generator [Wp]	420-900	300-900	300-900	300-900
battery operation	nominal voltage 48VDC			



System Sizing Table

Instructions

1. lift: Find the lift you require and read the column below it.
2. daily volume: Find the daily volume you require at an irradiation of 4.5, 6 or 7.5 kWh/m²/day. 7.5 is a moderately dry summer weather. For more water, look further down the column.
3. pipe sizing: Use peak flow rate for pipe sizing.
4. wire size, max. wire length

solar generator	vertical lift	5 m 16 ft		10 m 33 ft		15 m 50 ft		20 m 65 ft		30 m 100 ft		40 m 133 ft		50 m 165 ft		60 m 200 ft		70 m 230 ft					
	array mounting	fixed	tracked	fixed	tracked	fixed	tracked	fixed	tracked	fixed	tracked	fixed	tracked	fixed	tracked	fixed	tracked	fixed	tracked				
flow rate [m³/day]																							
300 Wp	irradiation kWh/m ² /day	7.5	45	65	19	27	19	26	15	22	7.5	9.5	6.2	8.7	6.0	7.9	4.7	6.8	3.8	5.3			
		6.0	38	52	15	22	15	20	11	16	6.2	8.2	5.4	7.4	4.8	6.3	3.7	5.3	3.0	4.2			
		4.5	29	38	12	16	11	15	7.0	9.0	5.0	6.8	4.5	6.0	3.5	4.7	2.8	3.8	2.3	3.0			
	pump type	C-SJ8-7			HR-14						HR-04						HR-03						
	peak flow rate [l/min]	110			47			40			36			14		13		11		7			
wire size/max. length	4mm ² / 45m #10 / 150ft																						
350 Wp	irradiation kWh/m ² /day	7.5	52	78	22	30	23	29	18	26	14	20	6.8	8.7	6.1	8.3	5.7	7.9	4.9	6.8			
		6.0	43	62	19	26	18	24	15	20	10	14	6.5	8.3	5.5	7.5	4.8	6.9	4.1	5.8			
		4.5	33	44	16	22	14	19	10	14	6.0	8.0	6.0	8.0	4.7	6.2	4.0	5.6	3.5	4.8			
	pump type	C-SJ8-7			HR-14						HR-04												
	peak flow rate [l/min]	125			47			40			36			30		13		13		11		10	
wire size/max. length	4mm ² / 45m #10 / 150ft																						
420 Wp	irradiation kWh/m ² /day	7.5	60	90	26	31	24	30	20	29	16	23	8.7	13	6.8	8.7	6.1	8.3	5.7	7.6			
		6.0	50	72	22	27	19	25	17	24	12	17	7.5	11	6.0	7.9	5.4	7.2	4.8	6.4			
		4.5	39	53	17	24	15	21	14	19	8.0	11	6.5	8.7	5.0	7.0	4.5	6.0	4.0	5.4			
	pump type	C-SJ8-7			HR-14						HR-07						HR-04						
	peak flow rate [l/min]	135			43			42			38			34		20		13		11		10	
wire size/max. length	4mm ² / 45m #10 / 150ft																						
480 Wp	irradiation kWh/m ² /day	7.5	66	95	34	49	30	43	22	30	18	26	14	16	11	16	8.7	13	6.1	8.7			
		6.0	56	80	28	38	24	32	19	27	15	19	10	14	8.5	12	7.0	10	5.5	7.4			
		4.5	44	60	22	28	18	24	15	21	12	16	7.0	9.5	5.5	7.5	5.0	6.5	4.5	6.0			
	pump type	C-SJ8-7			C-SJ5-8						HR-14						HR-07		HR-04 with #10/280ft		HR-04		
	peak flow rate [l/min]	145			80			75			42			36			28		20		19		13
wire size/max. length	6mm ² / 55m #10 / 130ft																						
660 Wp	irradiation kWh/m ² /day	7.5	82	112	60	86	38	57	26	30	22	29	17	25	14	19	9.8	14.4	8.7	12.5			
		6.0	71	98	50	70	32	46	23	29	18	24	14	19	11	15	8.5	12.0	7.3	10.5			
		4.5	56	74	36	47	24	33	19	25	14	19	10	14	8.0	10	7.0	9.5	6.0	8.5			
	pump type	C-SJ8-7			C-SJ5-8						HR-14						HR-07						
	peak flow rate [l/min]	165			135			90			43			42			40		38		20		20
wire size/max. length	4mm ² / 20m #10 / 85ft																						
720 Wp	irradiation kWh/m ² /day	7.5	87	125	66	93	42	61	33	47	24	30	20	29	18	26	11	14	10	14			
		6.0	76	106	54	78	35	50	26	36	20	26	18	25	14	19	10	14	9.0	13			
		4.5	59	80	39	53	25	34	22	30	17	23	16	21	9	12	9	12	8.0	11			
	pump type	C-SJ8-7			C-SJ5-8						HR-14						HR-07						
	peak flow rate [l/min]	175			145			95			75			44			43		39		20		20
wire size/max. length	4mm ² / 20m #10 / 85ft																						
840 Wp	irradiation kWh/m ² /day	7.5	96	133	74	110	57	85	40	60	24	30	22	30	19	27	11	14	10	15			
		6.0	84	110	63	91	45	65	33	47	22	29	21	28	16	23	10	14	9.8	14			
		4.5	68	92	46	62	30	41	25	34	20	26	18	24	13	18	9.5	13	9.0	13			
	pump type	C-SJ8-7			C-SJ5-8						HR-14						HR-07						
	peak flow rate [l/min]	185			170			150			95			45			43		39		20		20
wire size/max. length	4mm ² / 20m #10 / 85ft																						

System Voltage

48-72V nominal, e.g. 4-6 standard 12V modules wired in series, Voc 150V max.

Lift Limits

These systems are selected for optimum performance. To allow unexpected drawdown, each system can handle an additional 15% lift.

Wire Sizes

Cable layout is calculated to stay within 4% power loss.

Pump cable: example: 6mm²/55m = maximum allowable length (controller to pump) for the given wire size.

Variations of Wire Length

Longer: for each 50% increase, the next larger wire size is required.

Shorter: for each 33% decrease, the next smaller wire size is possible.

Array to controller: up to 6m/20ft: min. 4mm²/#10

Controller to low-water-probe: min. 1mm²/#18, 2-conductor

Vertical lifts higher than 100m/330ft

For lifts higher than 100m/330ft please compare the wire sizes of the PS1200 system. Due to higher system voltage use of smaller wire diameters is possible and might result in reduced overall system cost.

Calculation of Daily Water Volume

Daily volume is calculated by integrating real flow versus realistic solar (PV) output throughout the day.

Calculations include a 10% PV output degradation (heat, dirt etc.). Cable losses are included at maximum allowable length. The solar array is fixed at tilt angle = latitude of the location.

Irradiation: kWh/m²/day = peak sun hours/day

Flow rates may vary by +/- 10%

Conversion for Flow Rates

1 m ³	264 US Gal.
1 m ³	220 Imp. Gal.
1 l/min	0.264 US Gal./min
1 l/min	0.220 Imp. Gal./min

Conversion for Lift/Length

1 m	3.3 ft
-----	--------

1 lift

80 m 265 ft		90 m 300 ft		100 m 330 ft		120 m 400 ft		140 m 460 ft		160 m 530 ft		180 m 600 ft		200 m 660 ft		230 m 760 ft		vertical lift	solar generator
fixed	tracked	fixed	tracked	fixed	tracked	fixed	tracked	fixed	tracked	fixed	tracked	fixed	tracked	fixed	tracked	fixed	tracked	array mounting	

flow rate [m³/day]

3.2	4.7	2.6	4.2	2.5	3.8	2.3	3.4	1.9	2.7
2.6	3.7	2.1	3.1	1.8	2.7	1.6	2.3	1.3	1.8
1.9	2.6	1.5	2.1	1.1	1.6	0.9	1.3	0.7	0.9
HR-03									
6.4		6.1		5.7		5.3		4.9	
10mm ² / 120m #10 / 330ft					10mm ² / 120m #8 / 450ft				

3.8	5.1	3.4	5.0	3.2	4.7	3.0	4.3	2.7	4.0
3.3	4.4	3.0	4.0	2.7	3.9	2.5	3.3	2.0	2.9
2.8	3.8	2.6	3.5	2.2	3.0	1.7	2.3	1.3	1.8
HR-03									
8.3		7.6		7.2		6.8		6.4	
10mm ² / 120m #10 / 330ft					10mm ² / 120m #8 / 450ft				

4.7	6.9	4.5	5.4	4.0	5.0	3.7	5.0	3.0	4.2	2.3	3.2	1.7	2.4
3.9	5.5	3.7	4.7	3.2	4.2	3.0	4.1	2.5	3.4	2.0	2.7	1.4	1.9
3.0	4.0	2.9	3.9	2.4	3.3	2.3	3.2	2.0	2.7	1.7	2.2	1.0	1.4
HR-04H				HR-03				HR-03H					
9.5		7.9		7.6		7.2		6.8		6.1		5.3	
10mm ² / 120m #10 / 330ft					10mm ² / 120m #8 / 450ft					14mm ² / 180m #6 / 600ft			

5.7	8.2	5.5	8.0	5.0	7.0	4.5	6.5	3.3	4.5	2.8	4.0	2.3	3.0
4.8	6.7	4.4	6.5	3.8	5.3	3.4	4.8	3.0	4.0	2.4	3.3	1.9	2.5
3.9	5.2	3.3	4.5	2.6	3.5	2.2	3.0	2.6	3.5	1.9	2.5	1.5	2.0
HR-04H				HR-03				HR-03H					
12		11		10		9.5		7.2		6.4		5.7	
10mm ² / 100m #6 / 420ft					10mm ² / 140m					14mm ² / 180m #6 / 600ft			

8.0	11.5	6.5	8.0	5.5	7.8	5.1	7.4	4.5	6.4
6.5	9.2	5.5	7.4	4.9	6.7	4.0	5.8	3.5	5.0
5.0	7.0	4.5	6.0	4.3	5.5	3.0	4.2	2.5	3.5
HR-07		HR-04H							
19		13		13		12		12	
#8 / 265ft		10mm ² / 100m #6 / 420ft							

9.4	14	8.7	13	6.0	8.0	5.7	8.0	5.3	7.0
8.2	12	7.4	11	5.8	7.0	5.0	6.5	4.4	5.9
7.0	9.5	6.0	8.1	5.5	6.1	4.0	5.4	3.5	4.7
HR-07				HR-04H					
20		19		13		13		12	
10mm ² / 100m #8 / 300ft				10mm ² / 120m #6 / 500ft					

10	14	9.4	14	6.8	8.0	6.4	8.0	6.0	7.2
8.9	12	8.4	12	6.1	7.4	5.7	6.8	5.2	6.4
7.8	11	7.3	9.8	5.7	6.4	4.7	6.1	4.4	6.0
HR-07				HR-04H					
20		19		13		13		12	
10mm ² / 100m #8 / 300ft				10mm ² / 120m #6 / 500ft					

Conversion for Wire Sizes

AWG	mm ²
# 18	1
# 12	4
# 10	6
# 8	10
# 6	16

Table shows nearest larger metric cross section.

7.5	irradiation kWh/m ² /day	300 Wp
6.0		
4.5		
pump type		
peak flow rate [l/min]		
wire size/max. length		

7.5	irradiation kWh/m ² /day	350 Wp
6.0		
4.5		
pump type		
peak flow rate [l/min]		
wire size/max. length		

7.5	irradiation kWh/m ² /day	420 Wp
6.0		
4.5		
pump type		
peak flow rate [l/min]		
wire size/max. length		

7.5	irradiation kWh/m ² /day	480 Wp
6.0		
4.5		
pump type		
peak flow rate [l/min]		
wire size/max. length		

7.5	irradiation kWh/m ² /day	660 Wp
6.0		
4.5		
pump type		
peak flow rate [l/min]		
wire size/max. length		

7.5	irradiation kWh/m ² /day	720 Wp
6.0		
4.5		
pump type		
peak flow rate [l/min]		
wire size/max. length		

7.5	irradiation kWh/m ² /day	840 Wp
6.0		
4.5		
pump type		
peak flow rate [l/min]		
wire size/max. length		

2 daily volume

3 peak flow for pipe sizing

4 wire size, max. wire length

Dimensions and Weights

	dimensions					shipping dimensions			
	L	A	B	D	S	packaging	shipping volume	net weight	gross weight
	[mm]	[mm]	[mm]	[mm]	[in]	[mm]	[m ³]	[kg]	[kg]
Pump Unit (PU) (motor + pump end)									
HR-03, HR-03H, HR-04, HR-04H	780	595	185	96	G 1 ¼	850×160×150	0.0204	11.2	12.0
HR-07, HR-10, HR-14, HR-20	771	586	185	96	G 1 ¼	850×160×150	0.0204	11.5	12.3
C-SJ5-8	524	339	185	96	G 1 ½	660×160×150	0.0158	11.2	12.0
C-SJ8-7	684	499	185	96	G 2	660×160×150	0.0158	12.7	13.5
Controller									
PS600						450×250×240	0.0270	4.5	5.3

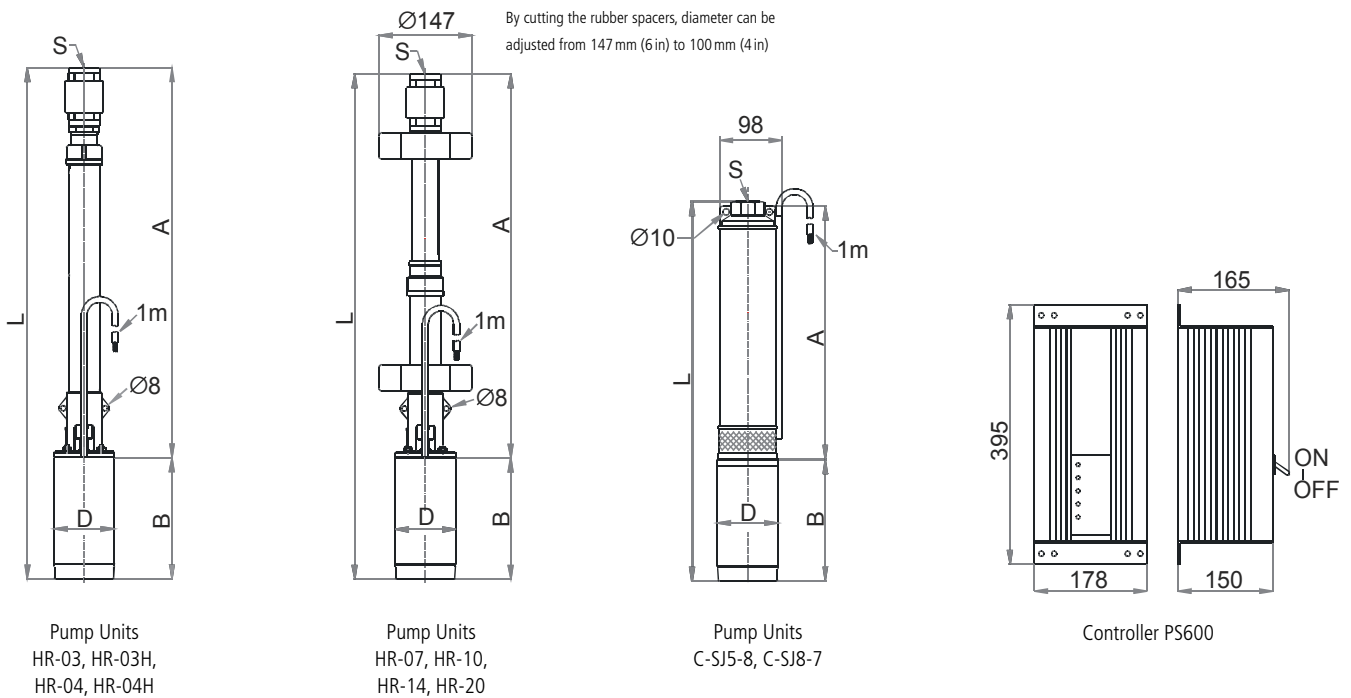

Sand and Silt Tolerance

The pump (HR) has a higher resistance to wear from sand, clay etc. than any other pump type. In properly constructed wells the amount of solid particles is within the tolerance of the pump.

A concentration of particles higher than 2% (by volume) may cause blockage in the pump or the drop pipe, especially at low flow rates.

Do not use the pump to clean out a dirty well.

Pump Cable and Splice

Standard submersible cable, 3-wire + ground (total four wires). Connection to the pump is made using industry-standard splicing methods.

Drop Pipe

G 1 ¼ in (optional: 1 in NPT) pump outlet. If water is dirty consider a smaller sized drop pipe to increase the flow velocity. This helps to exhaust solid particles and prevent accumulation in the pipe. When considering reduced pipe size, consult a pipe sizing (friction loss) chart. Pipe can be of any standard material, rigid or flexible. A torque arrestor is *not* required.

Temperature Limits

Pump end, motor: water temperature up to +40°C (+104°F)

Specify temperature range on order.

Controller: ambient temperature -30°C to +55°C (-22°F to +131°F)

Warranty

Two years manufacturer's warranty against defects in material and workmanship